

Anneau de levage StarPoint

Boulon à œillet orientable à 360° et chargeable avec plaque à clé pour un montage facile

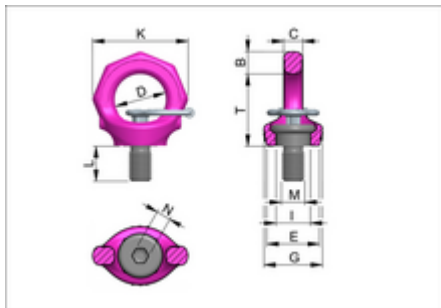

Nom court de l'article	WLL kg Angle 0° [kg]	WLL t angle 0° [t]	WLL kg Angle 90° [kg]	WLL t angle 90° [t]	B [mm]	C [mm]	D [mm]
VRS-F-M6	500	0.5	100	0.1	9	7	20
VRS-F-M8	800	0.8	300	0.3	11	9	25
VRS-F-M10	1000	1	400	0.4	11	9	25
VRS-F-M12	2000	2	750	0.75	13	10	30
VRS-F-M16	4000	4	1500	1.5	15	13	35
VRS-F-M20	6000	6	2300	2.3	17	16	40
VRS-F-M24	8000	8	3200	3.2	20	19	49
VRS-F-M30	12000	12	4500	4.5	26	24	60
VRS-F-M36	16000	16	7000	7	32	29	72
VRS-F-M42	24000	24	9000	9	37	33	84
VRS-F-M48	32000	32	12000	12	42	42	94

Nom court de l'article	E [mm]	G [mm]	I [mm]	K [mm]	L [mm]	M [mm]	N [mm]
VRS-F-M6	23	28	13	37	9	6	6
VRS-F-M8	25	30	16.3	47	12	8	6
VRS-F-M10	25	30	16.3	47	15	10	6
VRS-F-M12	30	34	19.8	56	18	12	8
VRS-F-M16	36	40	23.5	65	24	16	10
VRS-F-M20	41	50	29.3	76	30	20	12
VRS-F-M24	51	60	35	92	36	24	14
VRS-F-M30	66	75	44	114	45	30	17
VRS-F-M36	76	97	53	135	54	36	22
VRS-F-M42	86	111	62	158	63	42	24
VRS-F-M48	100	128	70	180	72	48	27

Nom court de l'article	T [mm]	Poids net [kg]
VRS-F-M6	28	0.07
VRS-F-M8	35	0.1
VRS-F-M10	34	0.1



Nom court de l'article	T [mm]	Poids net [kg]
VRS-F-M12	42	0.2
VRS-F-M16	49	0.3
VRS-F-M20	58	0.5
VRS-F-M24	70	0.9
VRS-F-M30	87	1.7
VRS-F-M36	103	2.9
VRS-F-M42	121	4.6
VRS-F-M48	138	7

NUMÉROS DE COMMANDE

WLL kg Angle 0°	VRS-F- M6	VRS-F- M8	VRS-F- M10	VRS-F- M12	VRS-F- M16	VRS-F- M20	VRS-F- M24	VRS-F- M30	VRS-F- M36	VRS-F- M42	VRS-F- M48
500 kg	2020836	-	-	-	-	-	-	-	-	-	-
800 kg	-	2020837	-	-	-	-	-	-	-	-	-
1000 kg	-	-	2020827	-	-	-	-	-	-	-	-
2000 kg	-	-	-	2020828	-	-	-	-	-	-	-
4000 kg	-	-	-	-	2020829	-	-	-	-	-	-
6000 kg	-	-	-	-	-	2020830	-	-	-	-	-
8000 kg	-	-	-	-	-	-	2020831	-	-	-	-
12000 kg	-	-	-	-	-	-	-	2020832	-	-	-
16000 kg	-	-	-	-	-	-	-	-	2020833	-	-
24000 kg	-	-	-	-	-	-	-	-	-	2020834	-
32000 kg	-	-	-	-	-	-	-	-	-	-	2020835

- Normes ISO 12100 EN 1677-1
- Matériel principal Acier
- Couleur Rose
- Plage de température -40° C to + 100° C
- Contenu des unités d'emballage (UE) 1

