

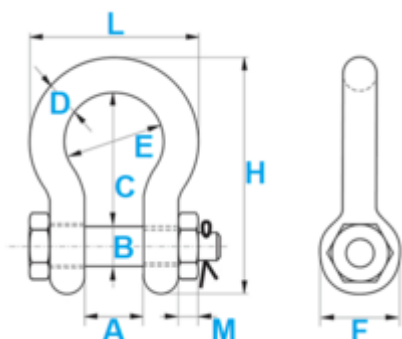

## Manille lyre à axe vissé Green Pin

Manille lyre avec axe vissé

Nom court de l'article	WLL [kg]	WLL [t]	A [mm]	B [mm]	C [mm]	D [mm]	E [mm]
GreenPin B SCP 0.33t	330	0.33	10	6	22	5	16
GreenPin B SCP 0.5t	500	0.5	12	8	29	7	20
GreenPin B SCP 0.75t	750	0.75	13	10	32	9	22
GreenPin B SCP 1t	1000	1	17	11	36.5	10	26
GreenPin B SCP 1.5t	1500	1.5	19	13	43	11	29
GreenPin B SCP 2t	2000	2	22	16	51	13.5	32
GreenPin B SCP 3.25t	3250	3.25	27	19	64	16	43
GreenPin B SCP 4.75t	4750	4.75	31	22	76	19	51
GreenPin B SCP 6.5t	6500	6.5	36	25	83	22	58
GreenPin B SCP 8.5t	8500	8.5	43	28	95	25	68
GreenPin B SCP 9.5t	9500	9.5	47	32	108	28	75
GreenPin B SCP 12t	12000	12	51	35	115	32	83
GreenPin B SCP 13.5t	13500	13.5	57	38	133	35	92
GreenPin B SCP 17t	17000	17	60	42	146	38	99
GreenPin B SCP 25t	25000	25	74	50	178	45	126
GreenPin B SCP 35t	35000	35	83	57	197	50	138
GreenPin B SCP 42.5t	42500	42.5	95	65	222	57	160
GreenPin B SCP 55t	55000	55	105	70	260	65	180



Nom court de l'article	F [mm]	H [mm]	Poids net [kg]
GreenPin B SCP 0.33t	12	36	0.03
GreenPin B SCP 0.5t	16.5	48.5	0.05
GreenPin B SCP 0.75t	20	56	0.1
GreenPin B SCP 1t	22.5	63.5	0.14
GreenPin B SCP 1.5t	26.5	74	0.19
GreenPin B SCP 2t	34	89	0.36
GreenPin B SCP 3.25t	40	110	0.63
GreenPin B SCP 4.75t	46	129	1.01
GreenPin B SCP 6.5t	52	144	1.5
GreenPin B SCP 8.5t	59	164	2.3
GreenPin B SCP 9.5t	66	185	3.24



Nom court de l'article	F [mm]	H [mm]	Poids net [kg]
GreenPin B SCP 12t	72	201	4.4
GreenPin B SCP 13.5t	80	227	6
GreenPin B SCP 17t	88	249	7.5
GreenPin B SCP 25t	103	300	14
GreenPin B SCP 35t	111	331	18.9
GreenPin B SCP 42.5t	130	377	26.3
GreenPin B SCP 55t	145	433	37.15



#### NUMÉROS DE COMMANDE

WLL	GreenPin B SCP 0.33t	GreenPin B SCP 0.5t	GreenPin B SCP 0.75t	GreenPin B SCP 1t	GreenPin B SCP 1.5t	GreenPin B SCP 2t	GreenPin B SCP 3.25t	GreenPin B SCP 4.75t	GreenPin B SCP 6.5t	GreenPin B SCP 8.5t	GreenPin B SCP 9.5t
0.33 t	2009122	-	-	-	-	-	-	-	-	-	-
0.5 t	-	2009123	-	-	-	-	-	-	-	-	-
0.75 t	-	-	2009124	-	-	-	-	-	-	-	-
1 t	-	-	-	2009125	-	-	-	-	-	-	-
1.5 t	-	-	-	-	2009126	-	-	-	-	-	-
2 t	-	-	-	-	-	2009127	-	-	-	-	-
3.25 t	-	-	-	-	-	-	2009128	-	-	-	-
4.75 t	-	-	-	-	-	-	-	2009129	-	-	-
6.5 t	-	-	-	-	-	-	-	-	2009130	-	-
8.5 t	-	-	-	-	-	-	-	-	-	2009131	-
9.5 t	-	-	-	-	-	-	-	-	-	-	2009132
12 t	-	-	-	-	-	-	-	-	-	-	-
13.5 t	-	-	-	-	-	-	-	-	-	-	-
17 t	-	-	-	-	-	-	-	-	-	-	-
25 t	-	-	-	-	-	-	-	-	-	-	-
35 t	-	-	-	-	-	-	-	-	-	-	-
42.5 t	-	-	-	-	-	-	-	-	-	-	-
55 t	-	-	-	-	-	-	-	-	-	-	-

WLL	GreenPin B SCP 12t	GreenPin B SCP 13.5t	GreenPin B SCP 17t	GreenPin B SCP 25t	GreenPin B SCP 35t	GreenPin B SCP 42.5t	GreenPin B SCP 55t
0.33 t	-	-	-	-	-	-	-
0.5 t	-	-	-	-	-	-	-
0.75 t	-	-	-	-	-	-	-
1 t	-	-	-	-	-	-	-
1.5 t	-	-	-	-	-	-	-
2 t	-	-	-	-	-	-	-
3.25 t	-	-	-	-	-	-	-
4.75 t	-	-	-	-	-	-	-
6.5 t	-	-	-	-	-	-	-
8.5 t	-	-	-	-	-	-	-
9.5 t	-	-	-	-	-	-	-
12 t	2009133	-	-	-	-	-	-
13.5 t	-	2009134	-	-	-	-	-



WLL	GreenPin B SCP 12t	GreenPin B SCP 13.5t	GreenPin B SCP 17t	GreenPin B SCP 25t	GreenPin B SCP 35t	GreenPin B SCP 42.5t	GreenPin B SCP 55t
17 t	-	-	2009135	-	-	-	-
25 t	-	-	-	2009136	-	-	-
35 t	-	-	-	-	2009137	-	-
42.5 t	-	-	-	-	-	2009138	-
55 t	-	-	-	-	-	-	2009139

■ Normes	EN 13889
■ Classe	60
■ Matériel principal	Acier
■ Couleur	Vert
■ Plage de température	-40° C to + 200° C
■ Plage de température	-40 °F to 392 °F
■ Contenu des unités d'emballage (UE)	1

